

			MAX		MAX		 2x 13
0110LCP2000	L1H1 (CH1)	0110LAG250	150 Kg	42 Kg	108 Kg	35'	
0110LHP2000	L1H2 (CH2)	0110LAG250	150 Kg	42 Kg	108 Kg	35'	
0110LEP2000	L2H1 (MH1)	0110LAG250	150 Kg	45 Kg	105 Kg	35'	
0110LAP2000	L2H2 (MH2)	0110LAG250	150 Kg	45 Kg	105 Kg	35'	
0110LDP2000	L3H2 (LH2)	0110LEG250	150 Kg	49 Kg	101 Kg	45'	

					SC-ASSPLATSTD			SC-FIXBLOC			SA-0110LAG						
					E M8x25	I Ø8 M	J M8 frein	F M8x50	I Ø8 Contact	J M8 frein	G M8x20	H M8x45	I Ø8 Contact	J M8 frein			
0110LAG250	6x	6x	6x	6x	1x	4x	8x	4x	3x	12x	24x	12x	3x	12x	6x	18x	18x
0110LAG250	6x	6x	6x	6x	1x	4x	8x	4x	3x	12x	24x	12x	3x	12x	6x	18x	18x
0110LAG250	6x	6x	6x	6x	1x	4x	8x	4x	3x	12x	24x	12x	3x	12x	6x	18x	18x
0110LAG250	6x	6x	6x	6x	1x	4x	8x	4x	3x	12x	24x	12x	3x	12x	6x	18x	18x
0110LEG250	8x	8x	8x	8x	1x	4x	8x	4x	4x	16x	32x	16x	4x	16x	8x	24x	24x

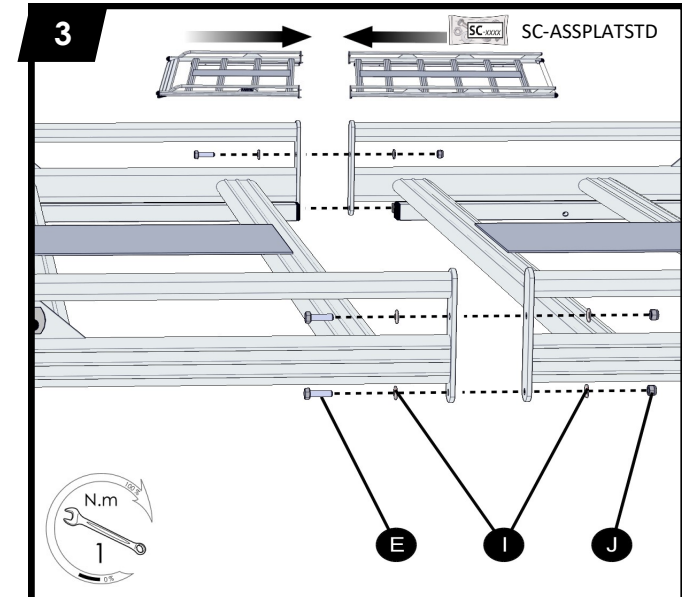

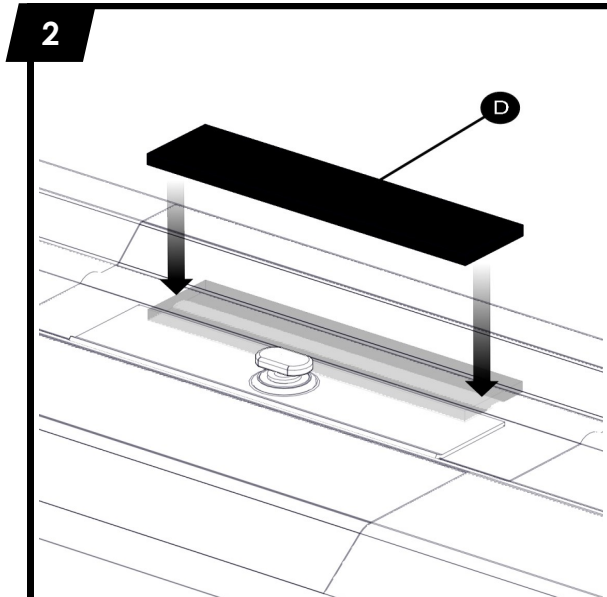

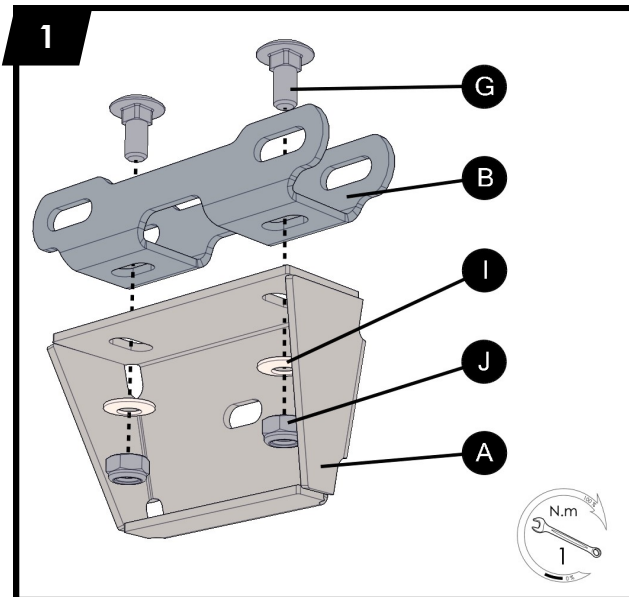
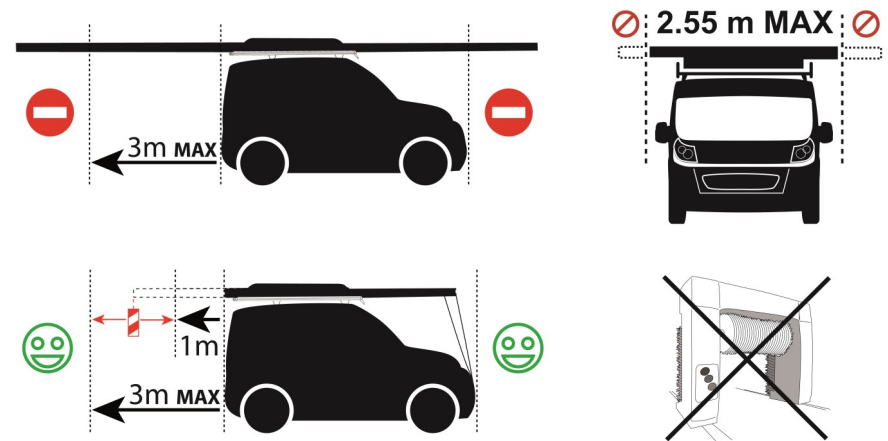
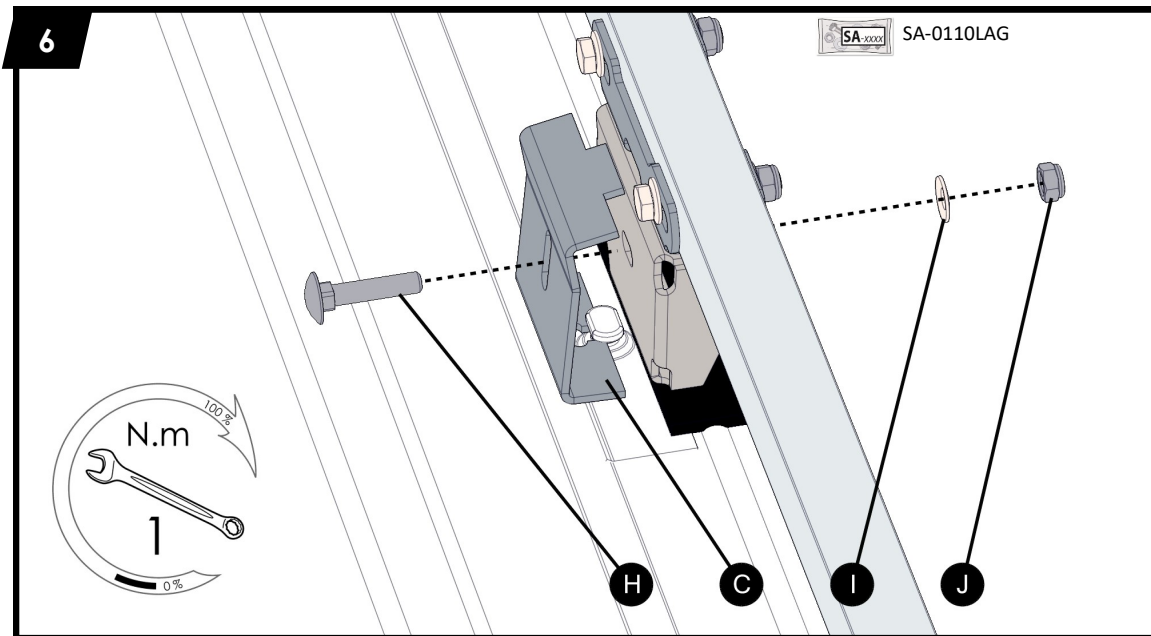
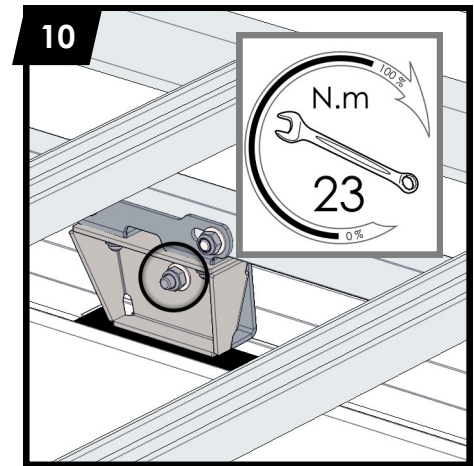
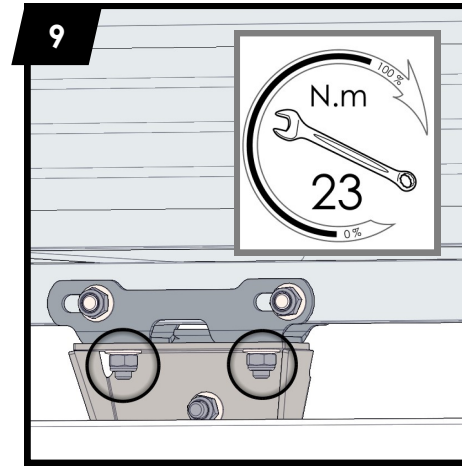
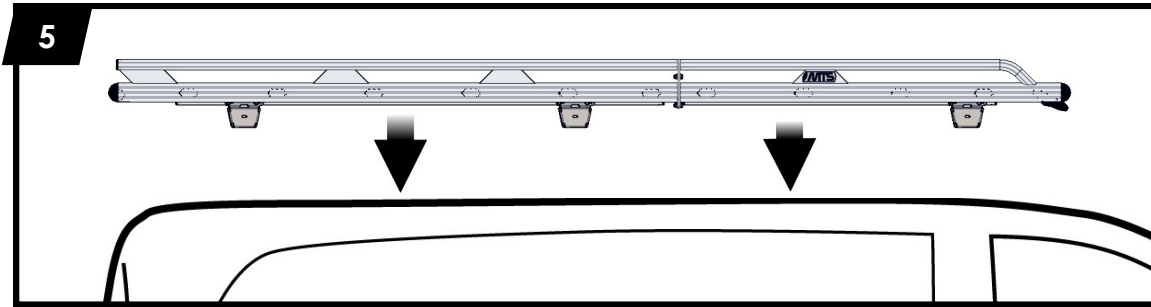
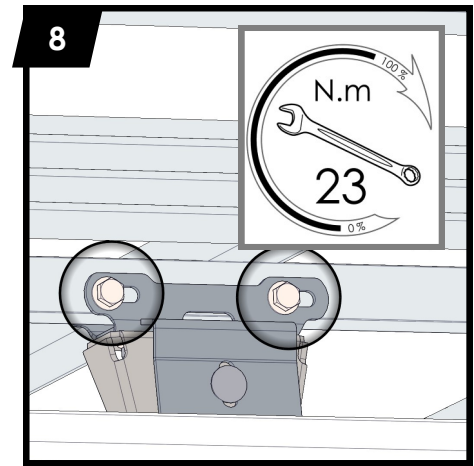
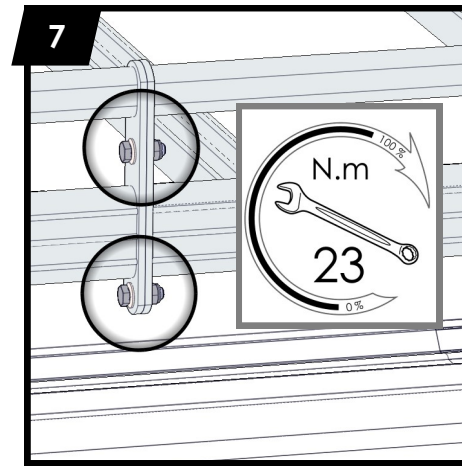
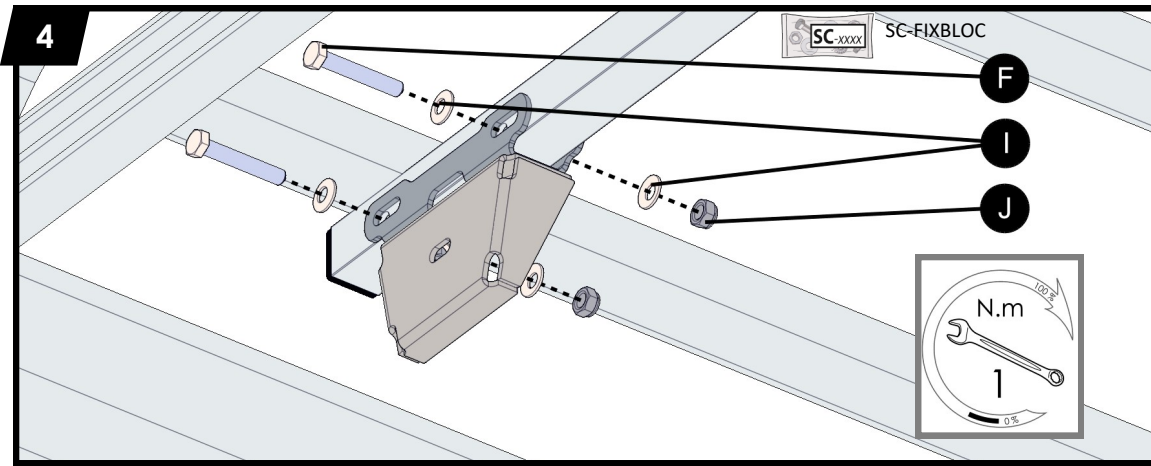

Fiat DUCATO Peugeot BOXER Citroën JUMPER

NTMG008 - Rev 2-C - 03/06/2020
0110 Ducato-Boxer-Jumper LLP-LSP-LXP ALU

0110LSP3000	L3H3	0110LSG200	150 Kg	39 Kg	111 Kg	40'	2x 13
0110LLP3000	L4H2		150 Kg	40 Kg	110 Kg	40'	
0110LXP3000	L4H3	0110LXG200	150 Kg	42 Kg	108 Kg	45'	

	A	B	C M8x25	D M8x45	E Ø8 M	F Ø8 DD	G M8 frein
0110LSG200	10x	10x	4x	10x	8x	10x	14x
0110LXG200	12x	12x	4x	12x	8x	12x	16x

